

# Monitoring and Control of *Oryza sativa* L (paddy) Cultivation using Wireless Sensor Network in LabVIEW

R. Maheswaran<sup>1</sup>, S. Muruganand<sup>2</sup>, B. Dinesh Kumar<sup>3</sup>

Research Scholar, Research and Development Centre, Bharathiar University, Coimbatore, TN, India<sup>1</sup>

Assistant Professor, Department of Electronics and Instrumentation, Bharathiar University, Coimbatore, TN, India<sup>2</sup>

Research Scholar, Department of Electronics and Instrumentation, Bharathiar University, Coimbatore, TN, India<sup>3</sup>

**Abstract:** In recent days, world population is incredibly growing. Day by day the need of food is increasing. Drought and water scarcity are the major problems that every farmer faces today. Farmers cannot detect the soil moisture, nutrients deficiency and diseases in paddy and wheat fields at the earliest. Farmers prefer other businesses rather than agriculture so the productivity is going down. The objective of proposed research is to monitor the growth of *Oryza sativa* L (Paddy) crops, Further, the technique is used to control the plant soil moisture and water level. This technique saves a lot of man power, increases the quality with quantity and feasible for precision agriculture. *Oryza sativa* L (Paddy) is most important food crops in the world. The above sensor results are transmitted through Wireless Sensor Network (ZIGBEE – TARANG F4) using LabVIEW software and PIC16F877A microcontroller for the further controlling process. The output of the proposed method is sent to the concerned person using GMAIL through Ethernet techniques.

**Keywords:** Soil moisture and, Water level sensor, LabVIEW, Wireless Sensor Network, PIC16F877and precision agriculture

## 1. INTRODUCTION

Advance in electronics and instrumentation increases the productivity in precision agriculture. *Oryza sativa* L (Paddy) is the most important food crops in the world [1]. Paddy is the staple foods for an approximate semi of the world population.

In Paddy and Wheat field, the diseases can be prevented and managed if the symptoms are identified in the early stages also it finds Nutrients deficiency and prevents the wastage of water. So this research work aims to focus on hybrid embedded system design for monitoring the growth of in *Oryza Sativa* L in real time [2]. The entire setup is controlled by LabVIEW graphical language program, Wireless Sensor Network (WSN).

## 2. RELATED WORK

Francisco G. Montoya et al. [3] reported that one of the most important changes in the southeast Spanish lands is the switch from traditional agriculture to agriculture based on the exploitation of intensive farmlands. For this type of farming, it is important to use techniques that improve plantation performance. Web applications, databases, and advanced mobile systems facilitate real-time data acquisition for effective monitoring.

Antonio-Javier Garcia-Sanchez et al. [4] presented that video-surveillance is a solution to detect and identify intruders as well as to better take care of the production process. In this paper, a new platform called Integrated WSN Solution for Precision Agriculture is proposed.

The only cost-effective technology employed is IEEE 802.15.4, and it efficiently integrates crop data acquisition, data transmission to the end-user and video-surveillance tasks. This platform has been evaluated for the particular scenario of scattered crops video-surveillance by using computer simulation and analysis.

Minzan Li et al. [5] reported that in order to accurately understand soil water deficit and therefore execute effective and water-saving irrigation, the distribution map of soil moisture was obtained by the integration of wireless sensor networks (WSN) with spatial analysis software. Jenna burrell et al. [6] discussed the grape field vineyard workers their work practices to access the potential for sensor network systems to aid work in the agriculture work environment. Agriculture works depends on seasons and time of day, so a sensor network that can self-configure according to temporal factors could combine some of these approaches.

Zhong Zhen-jiang et al. [7] designed to work as a wireless sensor network with one control unit and one measuring unit. The control unit included a personal digital assistant (PDA) device with a ZigBee wireless network coordinator. As the coordinator of the whole wireless network, the control unit was used to receive, display and store all the data sent from sensor nodes. The measuring unit consisted of several optical sensor nodes. All the sensor nodes were mounted on an on-board mechanical structure so that the measuring unit could collect the canopy spectral data while moving.

### 3. METHODOLOGY

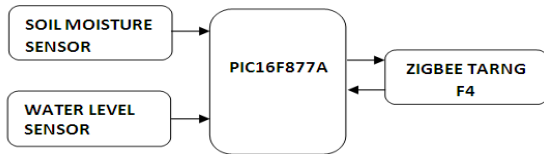

Fig.1. Block diagram of the proposed approach (Transmitter part)

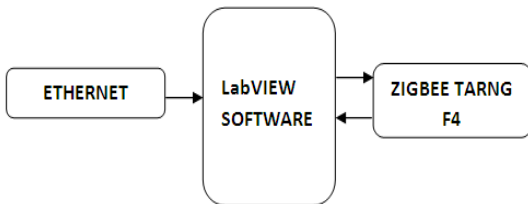

Fig.2. Block diagram of the proposed approach (Receiver part)

#### 3.1. LabVIEW

LabVIEW (Laboratory Virtual Instrumentation Engineering Workbench) is a platform and development environment for visual programming language from National Instruments [8, 9, and 10]. The graphical language is named as “G” language which is a unique tool implementation of the data flow programming model. In this, execution is determined by the structure of a graphical block diagram on which the programmer connects different functional nodes by drawing wires [11]. These wires propagate variables and any node can execute as soon as all input data become available. Since this might be the case for multiple nodes simultaneously, G is inherently exploited by the built-in scheduler, which multiplexes multiple OS, threads over the node, ready for execution.

LabVIEW ties the creation of user interfaces called front panels into the development cycle. LabVIEW programs are called Virtual Instruments (VIs) [12]. Each VI has three components a block diagram, a front panel, and a connector panel. The last is used to represent the VI I the block diagrams of other, called VIs.

Controls and indicators on the front panel allow an operator to input data or extract data from running virtual instruments. However, the front panel can also serve as a programmatic interface. Thus a virtual instrument can run as a program, with the front panel serving as a user interface, or, when dropped as a node onto the block diagram, the front panel defines the inputs and outputs for the given node through the connector panel. This implies each VI can be easily tested before being embedded as subroutine into a larger program.

Every VI display has an icon in the upper right corner of the front panel and block diagram windows. An icon is a graphical representation of a VI. It can contain text, images, or a combination of both. Use a VI as a sub-VI, the icon identifies the sub VI on the block diagram of the VI. To start with the programming in LabVIEW, one must have a clear idea on how the data flows in the project. This is because LabVIEW is a data flow based language [13].

Once the programmer has a clear idea of how data is moving. These might be either variable those that might change their values during the course of the program or constants, which remain fixed. Once the inputs are identified, place the icon that processes these inputs to give an output. If the input is variable, then a control such as a knob, slider or switch is placed on the front panel. This allows the user to vary the inputs as if in a real instrument. Now, the output of a signal icon might not be sufficient [14].

#### 3.2. WSN

The NI Wireless Sensor Network (WSN) platform delivers the flexibility to connect to a wide range of sensors for a variety of monitoring, testing, and measurement applications [15]. National Instruments has worked with a number of industry-leading sensor suppliers to make it even easier to configure and deploy wireless sensing solutions for applications such as monitoring the environment, water quality, power consumption, and resource usage. For each sensor listed below, National Instruments has tested its compatibility with the NI WSN platform. Each application note documents how to connect and use the sensor with the NI WSN nodes, and includes LabVIEW example code to illustrate the use of the sensor with NI WSN [16 and 17]

#### 3.3. TARNNG F4

ZigBee is the only standards-based wireless technology designed to address the unique needs of low-cost, low-power wireless sensor and control networks in just about any market. Since ZigBee can be used almost anywhere, is easy to implement and needs little power to operate, the opportunity for growth into new markets, as well as innovation in existing markets, is limitless

Tarang modules are designed with low to medium transmit power and for high-reliability wireless networks. The modules require minimal power and provide reliable delivery of data between devices. The interfaces provided with the module help to directly fit into many industrial applications. The modules operate within the ISM 2.4-2.4835 GHz frequency band with IEEE 802.15.4 baseband.



Fig.3. TARNNG F4

This module can be easily interfaced with any 8-bit microcontroller with all standard baud-rates between 1200 to 115200. Each module consists of a 16-bit address. So the user must provide a source address and destination address while configuring the module. Which means only the destination module with matched address can only receive the data.

The user can select the RF channels among 16 channels with addresses from 0x00 to 0x0F. The modules must be in the same channel to establish the communication between them.

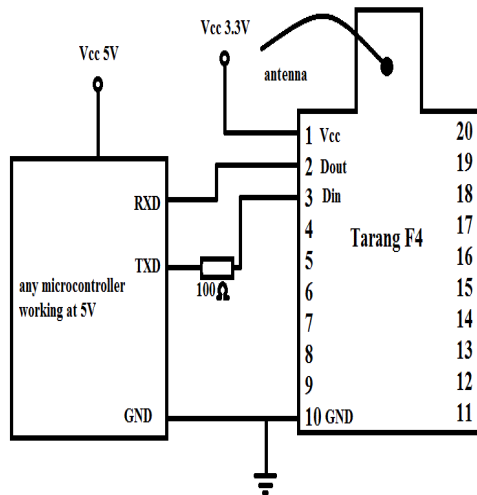

Fig. 4. Circuit diagram of the PIC16F877A and TRANGF4

### 3.4. PERIPHERAL INTERFACE CONTROLLER (PIC)

A microcontroller is a small computer on a single integrated circuit containing a processor core, memory and programmable input and output peripherals. A microcontroller is often described as a 'computer on a chip'.

PIC microcontroller is the first RISC (Reduce) based microcontroller fabricated in CMOS that uses the separate bus for instruction and data allowing simultaneous access of program and data memory [18]. The main advantage of CMOS and RISC combination is low power consumption resulting in a very small chip size with a small pin count.

### 3.4. SOIL MOISTURE and WATER LEVEL SENSOR

The soil moisture sensor measures the water content in the soil. The dielectric constant can be thought of as the soil's ability to transmit electricity [21 and 22]. The dielectric constant of the soil increases as the water content of the soil increases. Soil moisture probe is made up of multiple soil moisture sensors. This soil moisture sensor can be used to detect the moisture of soil or predict the water around the soil. This module can be inserted into the soil and then adjust the on-board potentiometer to adjust the sensitivity. The output of the sensor is logic HIGH/LOW when the moisture is higher/lower than the threshold set by the potentiometer [20].

The water level sensor is used for many requirements of liquid level measurement in an industrial application, such as in food, chemical, pharmaceutical and power generation

industries. Liquid level monitoring is also required for recharged areas [19]. In addition, the measurement is applied for early warning of the dry season in agriculture. There are various methods for measuring liquid level in the tank, vessel, container, and water resource.

The methods can be divided into two main categories: continuous level measurement for process monitoring and point level measurement to activate alarm or trip. The level measuring devices in both classes can be intrusive or non-intrusive. Many traditional techniques for liquid level measuring are based upon visual inspections, hydrostatic pressure, mechanical float system or displacer, bubblers, load cell, electrical property, thermal conductivity, capacitance, radiation-based level measurement, microwave, ultrasonic, optical [23]. Technologies commonly used in soil moisture sensors include: Frequency domain sensor such as a capacitance sensor. Neutron moisture gauges, utilize the moderator properties of water for neutrons. The electrical resistance of the soil Time domain transmission (TDT) [24] and time domain reflectometry (TDR); water has a high dielectric constant; a higher water concentration causes a higher average dielectric constant for the soil. The average dielectric constant can be sensed by measuring the speed of propagation along a buried transmission line. Heat dissipative sensor; Heat dissipation sensors rely on the effective heat R-value (insulation) of soil. Soil with additional water conducts heat more readily than dry soil. Measuring soil moisture is important in agriculture to help farmers manage their irrigation systems more efficiently. Not only are farmers able to generally use less water to grow a crop, they are able to increase yields and the quality of the crop by better management of soil moisture during critical plant growth stages [25].

Besides agriculture, there are many other disciplines using soil moisture sensors. Golf courses are now using sensors to increase the efficiencies of their irrigation systems to prevent over watering and leaching of fertilizers and other chemicals offsite [26].

In urban and suburban areas, landscapes and residential lawns are using soil moisture sensors to interface with an irrigation controller. Connecting a soil moisture sensor to a simple irrigation clock will convert it into a "smart" irrigation controller that prevents an irrigation cycle when the soil is wet. Exact measurement of soil moisture is needed for a variety of applications. In agriculture, proper growth, development, and maintenance of the plants depend very significantly on soil water content. Other applications range from monitoring of soil water content in various types of soil studies or in ecosystem management to geo-engineering where high soil water content can indicate potential danger of landslides. They all have in common a great need for precise measurement of the soil water content.

Water monitoring systems is a manufacturer of sensor systems that helps to optimize the management of water resources. As such, it has a number of transmitters for water-level measurement applications that operate through monitoring water pressure on a submerged sensor. With an EPDM rubber housing to protect the electronics, the SDX is an extremely durable sensor capable of level

measurements at three depths, 0-10 ft, 0-35 ft, and 0-50 ft, specified by the user at the time of purchase. Low depth units are ideal for open channel flow applications. Higher depth units are suitable for ground water, storage tank, or other similar applications. Some applications include well monitoring, ground water monitoring, surface water monitoring, soil & ground water remediation, and environmental impact studies.

#### 4. RESULTS AND DISCUSSION

The probe type soil moisture sensor is used for soil monitoring. This sensor voltage ranges from 0 to 2.5V for the determination of soil moisture. If the voltage drops below 1V, it is concluded that the field is dry. The moisture of the soil and water level are monitored simultaneously in which if the values of both the sensors are below the critical level indicates the warning of the scarcity of water in that particular field. In this emergency condition, the water is allowed to pass through the field by motor automatically.

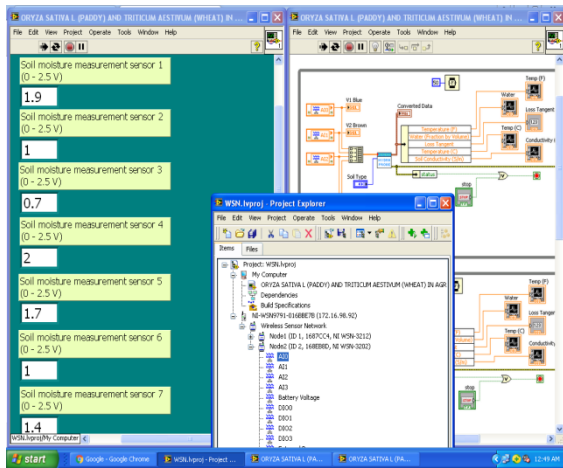

Fig. 5. The results of soil moisture sensor acquired from the field (3 acres)

Figure 5 show the different results from various soil moisture sensors placed in the field. Sensors 1,4,5,7 indicate the normal moisture content. Sensors 2, 6 show the reduced level of soil moisture. Sensor 3 indicates the dry level of moisture.

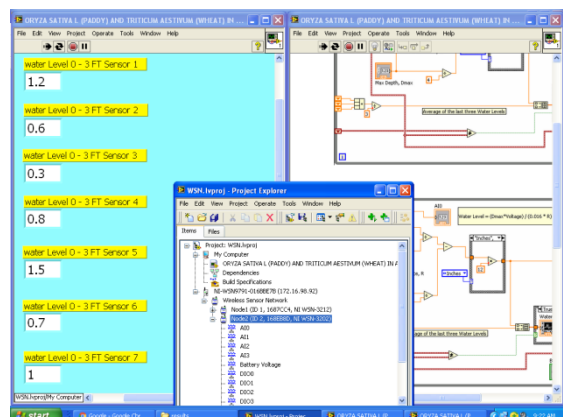

Fig. 6. The results of water level acquired from the field(3 acres)

Figure 5 show the level of water in the field. Sensors 1,4,5,7 indicate the normal water level. Sensors 2, 6 show the reduced level of water content. Sensor 3 indicates the very low level of water content in the field. Both the results clearly describes that the field of the sensors 3 is dry and others are in normal condition.

In a certain condition like reduced level or the moisture level of water is high the message is sent to the concerned person.



Fig. 7. Hardware setup in the field

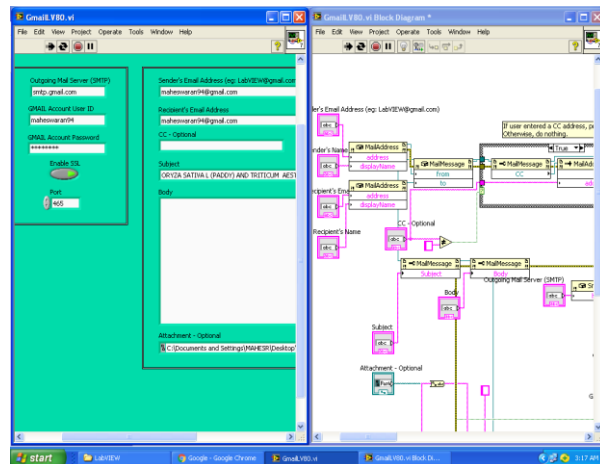

Fig. 8. Simple Mail Transfer Protocol (SMTP) for sending Email

Moreover, this result is sent through E – mail to the concerned person. Simple Mail Transfer Protocol (SMTP - Fig. 7) is used for sending Email.

#### 5. CONCLUSION

The growth of world population huddle the requirement of food crops (Oryza Sativa L.) is the major problem faced by the people in the world. Today, the major challenges in the cultivation of these crops are water drought, lack of nutrients, pesticides, infertility of soils etc. This research work addresses the water drought and soil moisture. In this research work moisture of the soil and water levels are being monitored directly from the field using WSN algorithm. These results are also sent to the farmer as well as the agriculture department through E – mail. So this hybrid embedded system design will be useful for the needs of today’s precision agriculture.

## REFERENCES

- [1] Georges Giraud, "The World Market of Fragrant Rice, Main Issues and Perspectives", *International Food and Agribusiness Management Review*, Vol.16, 2013. Hirsh, H., Coen, M.H., Mozer, M.C., Hasha, R. and Flanagan, J.L, "Room service, AI-style," *IEEE intelligent systems*, 14 (2), 8-19, Jul.2002.
- [2] The Department of Animal Husbandry, Dairying & Fisheries, Ministry of Agriculture, Government of India, "Annual Report", 2012-2013.
- [3] Francisco G. Montoya, Julio Gomez, Alejandro Cama, Antonio Zapata-Sierra, Felipe Martinez, Jose Luis De La Cruz, Francisco Manzano-Agugliaro, "A monitoring system for intensive agriculture based on mesh networks and the android system", *Computers and Electronics in Agriculture*, Vol.99, pp.14-20, 2013.
- [4] Antonio-Javier Garcia-Sanchez, Felipe Garcia-Sanchez, Joan Garcia-Haro, "Wireless sensor network deployment for integrating video-surveillance and data-monitoring in precision agriculture over distributed crops", *Computers and Electronics in Agriculture*, Vol.75, pp.288-303, 2011.
- [5] Man Zhang, Minzan Li, Weizhen Wang, Chunhong Liu, Hongju Gao, "Mathematical and Computer Modelling", *Mathematical and Computer Modelling*, Vol.58, pp.826-833, 2013.
- [6] Jenna Burrell, Tim Brooke, and Richard Beckwith, "Vineyard Computing: Sensor Networks in Agriculture Production", *IEEE Pervasive computing*, January – March 2004.
- [7] [23] ZHONG Zhen-jiang, SUN Hong, LI Min-zan, ZHANG Feng and LI Xiu-hua, "Development of a Vehicle-Mounted Crop Detection System", *Integrative Agriculture*, Vol. 13(6), pp.1284-1292, 2014
- [8] Haitao Xiang, Lei Tian, "An automated stand-alone in-field remote sensing system (SIRSS) for in-season crop monitoring", *Computers and Electronics in Agriculture*, Vol.78, pp.1-8, 2011.
- [9] M. Perez-Ruiz, P. Gonzalez-de-Santos, A. Ribeiro, C. Fernandez-Quintanilla, A. Peruzzi, M. Vieri, S. Tomic, J. Aguera, "Highlights and preliminary results for autonomous crop protection", *Computers and Electronics in Agriculture*, Vol.110, pp.150-161, 2015.
- [10] Daudi S. Simbeye, Jimin Zhao, Shifeng Yang, "Design and deployment of wireless sensor networks for aquaculture monitoring and control based on virtual instruments", *Computers and Electronics in Agriculture*, Vol.102, pp.31-42, 2014.
- [11] David Joseph Sampson, Young Ki Chang, H.P. Vasantha Rupasinghe, Qamar UZ Zaman, "A dual-view computer-vision system for volume and image texture analysis in multiple apple slices drying", *Food Engineering*, Vol.127, pp.49-57, 2014.
- [12] S. Viazzi, G. Ismayilova, M. Oczak, L.T. Sonoda, M. Fels, M. Guarino, E. Vranken, J. Hartung, C. Bahr, D. Berckmans, "Image feature extraction for classification of aggressive interactions among pigs", *Computers and Electronics in Agriculture*, Vol.104, pp.57-62, 2014.
- [13] Weilin Wang, Changying Li, Ernest W. Tollner, Glen C. Rains, "Development of software for spectral imaging data acquisition using LabVIEW", *Computers and Electronics in Agriculture*, Vol.84, pp.68-75, 2012.
- [14] E. Bauriegel, A. Giebel, M. Geyer, U. Schmidt, W.B. Herppich, "Early detection of Fusarium infection in wheat using hyperspectral imaging", *Computers and Electronics in Agriculture*, Vol.75, pp.304-312, 2011.
- [15] Antonio-Javier Garcia-Sanchez, Felipe Garcia-Sanchez, Joan Garcia-Haro, "Wireless sensor network deployment for integrating video-surveillance and data-monitoring in precision agriculture over distributed crops", Vol.75, pp. 288-303, 2011.
- [16] Antonio-Javier Garcia-Sanchez, Felipe Garcia-Sanchez, Joan Garcia-Haro, "Wireless sensor network deployment for integrating video-surveillance and data-monitoring in precision agriculture over distributed crops", *Computers and Electronics in Agriculture*, Vol.75, pp.288-303, 2011.
- [17] Aqeel-ur-Rehman, Abu Zafar Abbasi, Noman Islam, Zubair Ahmed Shaikh, "A review of wireless sensors and networks' applications in agriculture", *Computer Standards & Interfaces*, Vol.36, pp.263-270, 2014.
- [18] Jenna Burrell, Tim Brooke, and Richard Beckwith, "Vineyard Computing: Sensor Networks in Agriculture Production", *IEEE Pervasive computing*, January – March 2004.
- [19] Deqin Xiao, Jianzhao Feng, Ning Wang, Xiwen Luo, Yueming Hu, "Integrated soil moisture and water depth sensor for paddy fields", *Computers and Electronics in Agriculture*, Vol.98, pp.21-221, 2013.
- [20] Zhe Yin, Tingwu Lei, Qinghong Yan, Zhanpeng Chen, Yuequn Dong, "A near-infrared reflectance sensor for soil surface moisture measurement", *Computers and Electronics in Agriculture*, Vol.99, pp.101-107, 2013.
- [21] Saida Bedbabis, Dhouha Trigui, Chedlia Ben Ahmed, Maria Lisa Clodoveo, Salvatore Camposeo, Gaetano alessandro Vivaldi, Bechir Ben Rouina, "Long-terms effects of irrigation with treated municipal wastewater on soil, yield and olive oil quality", *Agricultural Water Management*, Vol.160, pp.14-21, 2015.
- [22] K. Chetpattananondh, T. Tapoanoi, P. Phukpattaranont, N. Jindapetch, "A self-calibration water level measurement using an interdigital capacitive sensor", *Sensors and Actuators A: Physical*, Vol.209, pp.175-182, 2014.
- [23] Stefanos A. Nikolidakis, Dionisis Kandris, Dimitrios D. Vergados, Christos Douligeris, "Energy efficient automated control of irrigation in agriculture by using wireless sensor networks", *Computers and Electronics in Agriculture*, Vol.113, pp.154-163, 2015.
- [24] G. Calamita, A. Perrone, L. Brocca, B. Onorati, S. Manfreda, "Field test of a multi-frequency electromagnetic induction sensor for soil moisture monitoring in southern Italy test sites", *Journal of Hydrology*, Vol.529, pp.316-329, 2015.
- [25] Nikhil Jorapur, Vinay S. Palaparthi, Shahbaz Sarik, Jobish John, Maryam Shojaei Baghini, G.K. Ananthasuresh, "A low-power, low-cost soil-moisture sensor using dual-probe heat-pulse technique", *Sensors and Actuators A: Physical*, Vol.233, pp.108-117, 2015.
- [26] Dan TerAvest, Lynne Carpenter-Boggs, Christian Thierfelder, John P. Reganold, "Crop production and soil water management in conservation agriculture, no-till, and conventional tillage systems in Malawi", *Agriculture, Ecosystems and Environment*, Vol.212, pp.285-296, 2015.